



Series PMI Particulate Matter Transmitter

Specifications - Installation and Operating Instructions



Wall mount



Wall mount with LCD



Duct mount



Duct mount with LCD

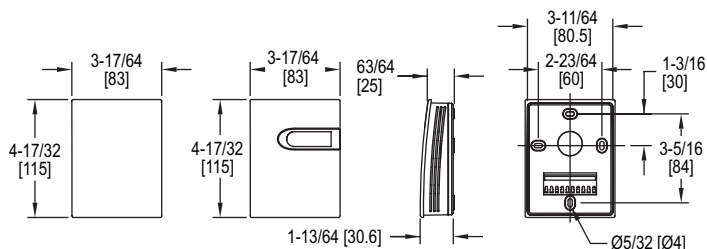

Wall mount

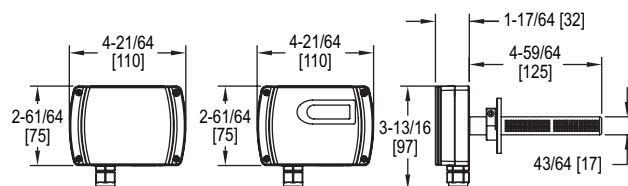

Duct mount

The **Series PMI Particulate Matter Transmitter** is designed to measure indoor air quality by detecting particulate matter in an office environment or HVAC duct. Using laser scattering technology, the Series PMI can measure particles as small as 0.3 μm , making it an essential component of any indoor air quality monitoring system. The optional relay combined with the settable alarm and control parameters allow the Series PMI to be a stand-alone controller.

BENEFITS/FEATURES

- Maintains healthy air supply with long term stability and accuracy
- Particulate matter application independent as duct and wall mount units are available
- Low maintenance with 10 years of service life in auto mode
- Minimal downtime with overvoltage protection
- Easy setup with optional integral display and buttons
- Saves time using removable terminal block on duct mount model
- Single unit controller with alarm, control modes, and optional relay

APPLICATIONS

- Educational institutions
- Healthcare facilities
- Corporate offices
- Hotels/restaurants
- Air purifiers

SPECIFICATIONS

Sensor: Laser scattering.
Range: PMI-2.5: 0-500 $\mu\text{g}/\text{m}^3$, particle size 0.3-2.5 μm ; PMI-10: 0-600 $\mu\text{g}/\text{m}^3$, particle size 0.3-10 μm .
Accuracy: $\pm 10 \mu\text{g}/\text{m}^3$ @ 0-100 $\mu\text{g}/\text{m}^3$; $\pm 10\%$ reading @ 100-600 $\mu\text{g}/\text{m}^3$ @ 25°C, 50% RH.
Resolution: 1 $\mu\text{g}/\text{m}^3$.
Response Time: <10 s, continuous service mode.
Temperature Limits: Operating: 32 to 122°F (0 to 50°C); Storage: -22 to 158°F (-30 to 70°C).
Humidity Limits: 0-95% RH (non-condensing).
Power Requirements: 16-28 VAC/6-35 VDC.
Load Resistance: Current output: $\leq 500 \Omega$; Voltage output: $\geq 2 \text{ k}\Omega$.
Output: Current: 4-20 mA; Voltage: 0-10 VDC; Relay: SPST 3A, 30 VDC/250 VAC; RS-485/Modbus® (RTU).
Service Life: MTBF more than 3 years in continuous service mode, service life up to 8-10 years in auto (intermittent) service mode.
Display: Optional 4-digit LCD.
Housing Materials: Wall mount: Polycarbonate (UL 94 V-0); Duct mount: ABS and polycarbonate (UL 94 V-0).
Enclosure Rating: Wall mount: IP30; Duct mount: IP65 (housing), IP30 (probe).
Weight: Wall mount: 7.05 oz (200 g); Duct mount: 9.5 oz (270 g).
Compliance: CE, UKCA.

INSTALLATION

CAUTION Hazard of eye injury. This product uses a laser particulate matter sensor and it is strictly prohibited to disassemble the unit. Direct laser exposure is hazardous.

NOTICE Use electrostatic discharge precautions (e.g., use of wrist straps) during installation and wiring to prevent equipment damage.

NOTICE Avoid locations where severe shock or vibration, excessive moisture or corrosive fumes are present.

This product is suitable for common environment measurement. If it is installed in an environment exceeding the acceptable measurement range for a long period of time, it may lead to the decrease of the measurement accuracy. In any environment with high humidity, high temperature, smoke, etc., the performance of the sensor may also be decreased due to excessive contaminants, such as dust and oil mist, etc.

Choose a location with good ventilation and without strong light or vibration. Direct light or vibration can affect the accuracy of the sensor.

The unit should be powered OFF during installing and wiring. When using 24 VAC, it is strongly recommended to power the unit with an independent transformer. If sharing a 24 VAC transformer with other equipment, such as controllers, transmitters or actuators, please make sure the terminals 24 V and GND are connected correctly to avoid equipment damage that is not covered under warranty.

Surface Mounting:

The wall mount models should be installed vertically on a flat surface. The installation site should be far away from any heater, cooler, fan, humidifier, dehumidifier, and other heat/cool/humidity sources. To mount the transmitter:

- Use a flathead screwdriver and insert it into the snap at the upper side of the housing. Push down gently and then open the front cover.
- Feed the cable into the housing before installing the base on the wall according to the diagram inside the front cover.
- Finish electrical connection according to the wiring diagram in Figure 3.
- Snap the front cover back into place and finish the installation.

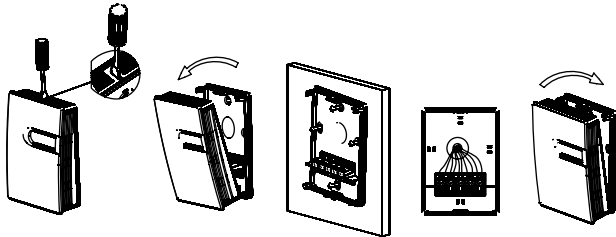

Figure 1

Duct Mounting

NOTICE During assembly, installation, and wiring, all seal rings must be applied properly and securely to ensure the whole enclosure, including where the probe and duct meet, will be sealed. This is the only way to prevent leaks from air sources other than the air sampling vents/holes and maintain the IP65 rating.

To duct mount the transmitter:

- First, the probe must be attached to the back of the enclosure as shown in Figure 2A by inserting the provided black seal ring in the groove located on the back of the housing. Next, align the probe latches with the cutouts on the back of the housing and gently turn it according to the direction indicated on the probe until it snaps into place.
- Mount using one of the following ways, ensuring that all sampling holes on the probe are inserted into the duct and that the direction indicated on the front cover is the same as the direction of the air flow inside of the duct.
 - To install via the flange as shown in Figure 2B, drill a $\text{Ø}19$ mm hole in the duct, install the seal ring and the flange onto the duct using three of the four provided shorter screws. Then, insert the probe into the duct. Use the last provided short screw to lock the whole enclosure onto the flange.
 - To install the enclosure directly on the duct as shown in Figure 2C, drill a $\text{Ø}19$ mm hole on the duct, insert the probe with the seal ring, and screw the enclosure on the duct directly using the two longer screws provided.
- Remove the four screws from the front cover and lift to access the wiring. Wire according to the wiring diagram inside the front cover. Once completed, replace the front cover.

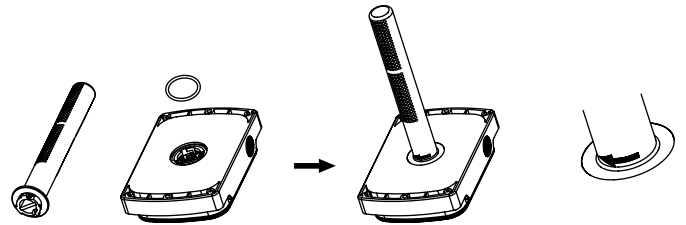

Figure 2A

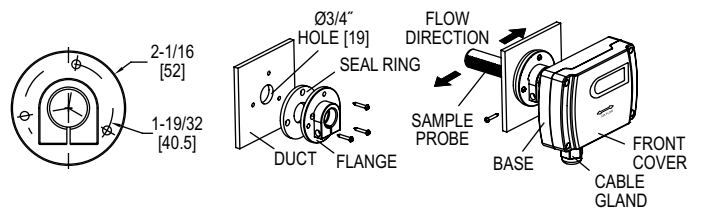

Figure 2B

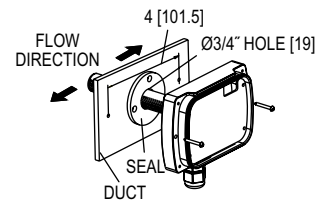

Figure 2C

ELECTRICAL

NOTICE Different models have different electrical terminals. Please wire specific model according to the wiring diagram inside the front cover.

CAUTION Disconnect power supply before installation to prevent electrical shock and equipment damage.

Make sure all connections are in accordance with the job wiring diagram and in accordance with national and local electrical codes. Use copper conductors only.

CAUTION Do not exceed ratings of this device, permanent damage not covered by warranty may result.

Outputs

Shown in Figure 3 below is an example of a communication terminal block. Analog only models will not include terminals 5 and 6. Terminal 3 is the 0-10 V output and terminal 4 is the 4-20 mA output. For RS-485/Modbus® communication refer to the **RS-485 COMMUNICATIONS/Modbus® RTU** section later in the manual.

Terminals 9 and 10 close when relay 1 is on. Terminals 9 and 10 open when relay 1 is off. For relay output setting, refer to **Setting Parameters** section.

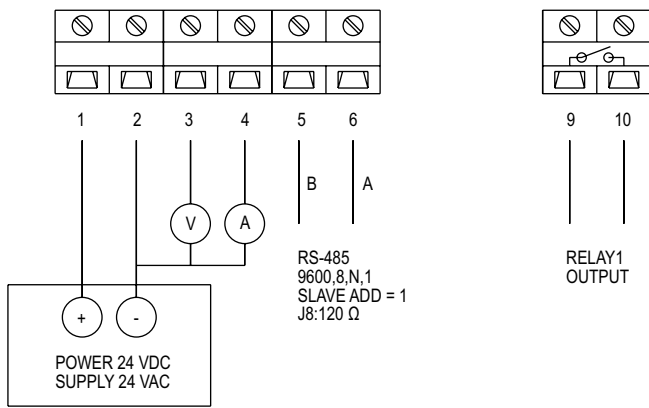

Figure 3: Communicating and analog terminal board

Jumpers

Figure 4 shows the RS-485 terminal resistance jumper J8 description as follows:

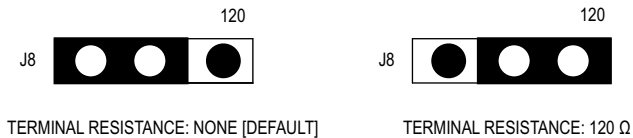

Figure 4

The Series PMI has two working modes, automatic mode (AUTO) and continuous mode (NORMAL). AUTO mode will automatically reduce the measuring time to extend the service life of the sensor when the environment's dust concentration changes very slightly. Use the MODE jumper shown in Figure 5 to choose the desired mode. The factory default mode is AUTO.

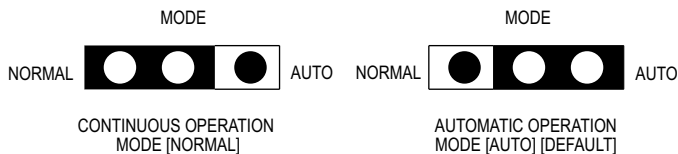

Figure 5

OPERATION

NOTICE LCD display with buttons is only available for wall mount units and does not apply for duct mount units.



BUTTON FUNCTIONS	
Button	Function
	Set/Save
	Adjust/Increase
	Bit Select/Decrease

Below are the corresponding instructions to set the parameters. The backlight of the LCD will turn off after 30s without any key operation. The LCD will display "----" when the settings are successful, and display "Err" when failed.

Setting Parameters (Applicable for LCD display with buttons only)

Use the following instructions to set the transmitter parameters. Push to enter programming mode. The display should read "P000". Then push to select the digit and push to cycle through 0-9; follow the instructions below to enter the corresponding parameter group settings.

Reset

→ P000 → / → P999 → → "rSt" → → finish.
To reset the unit to factory default settings: input "P999", then press button to display "rSt". Press the button . All factory default settings will be restored.

Check LCD backlight, LCD display, Relay Test Screen

→ P000 → / → P083 → → display "0123" LCD backlight on/off, LCD segments display normally and relay functions properly → → finish.

PMI2.5 display range (Default 0, 500)

→ P000 → / → P091 → → XX(1) → / → XX(1) → → XX(2) → / → XX(2) → finish.
XX(1) means low range and XX(2) means high range

PMI2.5 1 point calibration

→ P000 → / → P161 → → X.X → / → X.X → finish.
XX means calibration offset value.
Press key to finish and display the temperature single point calibration offset. After 2 seconds, the display temperature will read the value; the display value (output) = actual measurement + offset

Relay 1 setting (default set: 2, 100, 5, 3, 1, for models with a relay)

Minimum of 100; Maximum equals Max Range
 → P000 → / → P401 → → XX(M) → / → XX(M) → → XX(P1) → / → XX(P1) → → XX(P2) → / → XX(P2) → → XX(P3) → / → XX(P3) → → XX(P4) → / → XX(P4) → finish.

XX (M) means Mode; XX (P1) means Parameter #1; XX (P2) means Parameter #2; XX (P3) means Parameter #3; XX (P4) means Parameter #4; refer to descriptions in Table 1.

The symbol "R1" will show on the display when relay 1 is actuated.

Mode	Mode Description	Parameter #1	Parameter #2	Parameter #3	Parameter #4	Definition
0	Cancel relay alarm function	N/A	N/A	N/A	N/A	RELAY OFF
1	Relay actuate when input is lower than set point	Set point	Deadband	Start delay	Stop delay	
2	Relay actuate when input is higher than set point	Set point	Deadband	Start delay	Stop delay	
3	Relay actuate between high and low limits	Low limit	High limit	Start delay	Stop delay	
4	Relay actuate outside high and low limits	Low limit	High limit	Start delay	Stop delay	

Table 1: Relay descriptions

Set RS-485 baud rate (Default set: 9600, available 4800, 9600)

◇ → P000 → ▷ / △ → P483 → ◇ → XX → ▷ / △ → XX → ◇ finish.
 XXX means baud rate.

Set RS-485 parity (Default set: 0(None), available 0(None), 1(Odd), 2(Even))

◇ → P000 → ▷ / △ → P484 → ◇ → XX → ▷ / △ → XX → ◇ finish.
 XXX means parity.

Set RS-485 address (Default set: 1, available ranges 1-255, but recommend 1-32)

◇ → P000 → ▷ / △ → P485 → ◇ → XX → ▷ / △ → XX → ◇ finish.
 XXX means address.

ERROR MESSAGES

The following error messages will appear if an LCD is present and the device is an error state.

LCD ERROR MESSAGES		
Error Code	Possible Problem	Solution
Err	Button input error	Try a different input value
Er4	Sensor reading is abnormal	Verify sensor is plugged in correctly

RS-485 COMMUNICATIONS/Modbus® RTU

Communication settings:

- Baud rate: 9600
- Data: 8 Bit
- Stop: 1
- Parity: None
- Protocol: Modbus® RTU/RS-485

A typical Modbus® RTU mode message frame is shown below. In Modbus® RTU mode, the messages between frames are separated by no activity of at least the time interval of 3.5 characters. If the no activity interval between two characters is more than the time of 3.5 characters, the previous character was transferred successfully, and the current character's transmission starts.

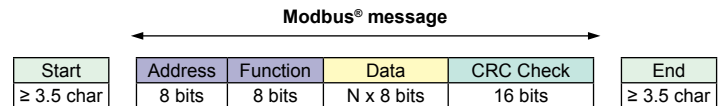

Modbus® Address

The message's first frame field is the device's address. Modbus® can support up to 256 different addresses, including valid addresses from 1-247. Address 0 is for broadcast and addresses 248-255 are reserved for special addresses. Slave address can be set with compatible Modbus® RTU software. The default address is 1. It is suggested each single loop be less than 32 devices.

Modbus® Function

The function code is the second data in the frame. Valid function codes are from 0-127 (01H-7FH). See the relevant Modbus® standard.

The Series PMI supports 03H/06H function codes, shown as the following Modbus® Poll software. The detail register addresses are in the **General Register Table** found on the next page.

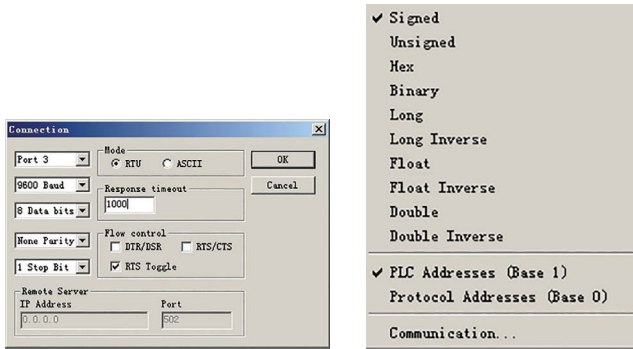

Figure 6

03H Read Holding Register

Example: Use the 03 function code to read the measurement value
As shown in Figure 8:

Slave address: 5
Function: 03
Started register: 40002
Register reading length: 2
Scan rate: 200 ms
Communication codes:
Master/PC to SLAVE: 05 03 00 01 00 02 94 4F
SLAVE to Master/PC: 05 03 04 00 FA 01 F4 9F D5

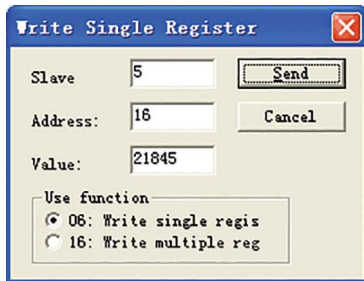

Figure 7

06H Preset Single Register

Example: restore factory settings.
As shown in Figure 7:

Slave address: 5
Function: 06
Register: 40016
Set value: 21845
Communication code:
Master/PC to SLAVE: 05 06 00 0F 55 55 47 22
SLAVE to Master/PC: 05 06 00 0F 55 55 47 22

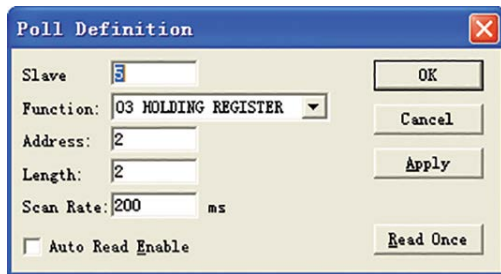

Figure 8

Broadcast mode to write data to slave

Using broadcast mode, the user can write data to all slaves connected to the network. The address of broadcast mode to write data is 0.

Example: To change slave address with broadcast mode, the user can set a new slave address.

Note: Since this operation will modify all the addresses of the slaves to the same address, it is NOT applicable for a network of more than one slave.

As shown in Figure 9, the slave address is changed to 3 by using broadcast mode:

Slave address: 0
Function: 06
Register address: 40014
Set value: 3
Communication codes:
Master/PC to SLAVE: 00 06 00 0D 00 03 59 D9
SLAVE to Master/PC: none

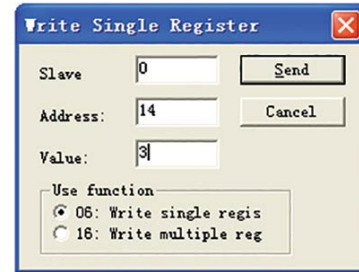

Figure 9

Special mode to read data from slave

With the special mode, the user can read the register data under the circumstance of NOT knowing the slave address.

Address of special mode read data: 255(0xFF)

Note: This operation is applicable for ONLY ONE slave in the network.

As shown in Figure 10 is a special mode to read slave address:

Slave address: 255(0xFF)
Function: 03
Started register: 40014
Register reading length: 1
Communication codes:
Master/PC to SLAVE: FF 03 00 0D 00 01 59 D9
SLAVE to Master/PC: FF 03 02 00 01 9F D5

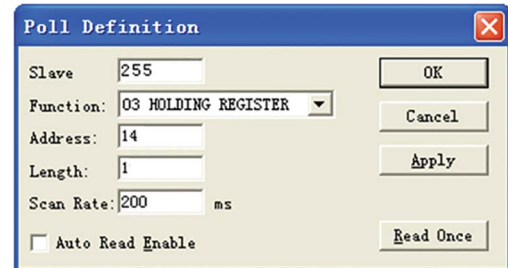

Figure 10

GENERAL REGISTER TABLE					
Register Address	R/W	Type	Definition	Remarks	
40001, 00000 0x0000	R	Signed	Product code	PMI series product code: 9070	
40002, 00001 0x0001	R	Signed	PM2.5 value	PMI2.5 = Value, ug/m ³	
40003, 00002 0x0002	R	Signed	PM10 value	PMI10 = Value, ug/m ³	
40014, 00013	R/W	Signed	RS-485/Modbus® RTU slave address	Default slave address =1, RTU,9600,n,8,1)	
40016, 00015	R/W	Signed	Function register	Write 40016=21845 to reset to factory default setting 0: Off 1: Relay activated below the set point 2: Relay activated higher than set point 3: Relay activated in the set range 4: Relay activated outside the set range	
40017, 00016	R/W	Signed	Relay control mode	Relay control parameters set	
40018, 00017	R/W	Signed	Back up	Relay control parameters set	
40019, 00018	R/W	Signed	Set point (mode 1 or 2) low limit (mode 3 or 4) regional	Relay control parameters set	
40020, 00019	R/W	Signed	Deadband (mode 1 or 2) high limit (mode 3 or 4)	Relay control parameters set	
40021, 00020	R/W	Signed	Start delay	Relay control parameters set	
40022, 00021	R/W	Signed	Stop delay	Relay control parameters set	
40029, 00028	R/W	Signed	Baud rate	Baud rate: 9600(default) or 4800	
40030, 00029	R/W	Signed	Parity	Parity: 0: NONE, 1: ODD, 2: EVEN	

Note:

- 40001 is PLC mode ADDRESS (BASE 1); 00000 is PROTOCOL ADDRESS (BASE 0).
- Function register 40016: Use the 06 function code to write password (21845) to the register 40016 to return to the factory set.

MAINTENANCE/REPAIR

Upon final installation of the Series PMI, no routine maintenance is required. The Series PMI is not field serviceable and it is not possible to repair the unit. Field repair should not be attempted and may void warranty.

WARRANTY/RETURN

Refer to "Terms and Conditions of Sale" in our catalog and on our website. Contact customer service to receive a Return Materials Authorization (RMA) number before shipping the product back for repair. Be sure to include a brief description of the problem plus any additional application notes.

MODEL CHART						
Model	Particulate Size	Mounting	Output	Relay	LCD Display	Buttons
PMI-2.5WC-N-N	PM 2.5	Wall mount	Modbus®, 4-20 mA, 0-10 V	No	No	No
PMI-2.5WC-N-LCD	PM 2.5	Wall mount	Modbus®, 4-20 mA, 0-10 V	No	Yes	No
PMI-10WC-N-N	PM 10	Wall mount	Modbus®, 4-20 mA, 0-10 V	No	No	No
PMI-10WC-N-LCD	PM 10	Wall mount	Modbus®, 4-20 mA, 0-10 V	No	Yes	No
PMI-2.5DC-N-N	PM 2.5	Duct mount	Modbus®, 4-20 mA, 0-10 V	No	No	No
PMI-10DC-N-N	PM 10	Duct mount	Modbus®, 4-20 mA, 0-10 V	No	No	No
PMI-2.5WC-RLY-LCD	PM 2.5	Wall mount	Modbus®, 4-20 mA, 0-10 V	Yes	Yes	No
PMI-10WC-RLY-LCD	PM 10	Wall mount	Modbus®, 4-20 mA, 0-10 V	Yes	Yes	No
PMI-2.5WC-RLY-B	PM 2.5	Wall mount	Modbus®, 4-20 mA, 0-10 V	Yes	Yes	Yes
PMI-10WC-RLY-B	PM 10	Wall mount	Modbus®, 4-20 mA, 0-10 V	Yes	Yes	Yes
PMI-2.5WA-RLY-B	PM 2.5	Wall mount	4-20 mA, 0-10 V	Yes	Yes	Yes
PMI-10WA-RLY-B	PM 10	Wall mount	4-20 mA, 0-10 V	Yes	Yes	Yes
PMI-2.5WC-RLY-N	PM 2.5	Wall mount	Modbus®, 4-20 mA, 0-10 V	Yes	No	No
PMI-10WC-RLY-N	PM 10	Wall mount	Modbus®, 4-20 mA, 0-10 V	Yes	No	No
PMI-2.5WA-N-LCD	PM 2.5	Wall mount	4-20 mA, 0-10 V	No	Yes	No
PMI-10WA-N-LCD	PM 10	Wall mount	4-20 mA, 0-10 V	No	Yes	No
PMI-2.5WA-N-N	PM 2.5	Wall mount	4-20 mA, 0-10 V	No	No	No
PMI-10WA-N-N	PM 10	Wall mount	4-20 mA, 0-10 V	No	No	No
PMI-2.5WA-N-B	PM 2.5	Wall mount	4-20 mA, 0-10 V	No	Yes	Yes
PMI-10WA-N-B	PM 10	Wall mount	4-20 mA, 0-10 V	No	Yes	Yes
PMI-2.5WC-N-B	PM 2.5	Wall mount	Modbus®, 4-20 mA, 0-10 V	No	Yes	Yes
PMI-10WC-N-B	PM 10	Wall mount	Modbus®, 4-20 mA, 0-10 V	No	Yes	Yes
PMI-2.5DA-N-N	PM 2.5	Duct mount	4-20 mA, 0-10 V	No	No	No
PMI-10DA-N-N	PM 10	Duct mount	4-20 mA, 0-10 V	No	No	No
PMI-2.5DA-N-LCD	PM 2.5	Duct mount	4-20 mA, 0-10 V	No	Yes	No
PMI-10DA-N-LCD	PM 10	Duct mount	4-20 mA, 0-10 V	No	Yes	No
PMI-2.5DC-N-LCD	PM 2.5	Duct mount	Modbus®, 4-20 mA, 0-10 V	No	Yes	No
PMI-10DC-N-LCD	PM 10	Duct mount	Modbus®, 4-20 mA, 0-10 V	No	Yes	No

